

IKD Series

Technical Manual | Digital Input-Output
Expansion Board

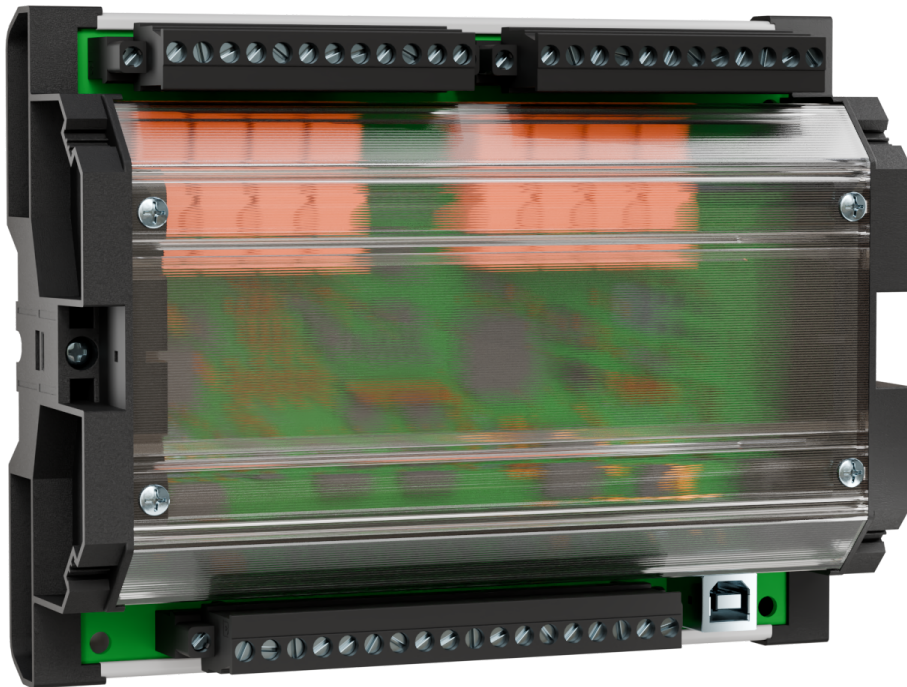

IKD2M-8/8

Release 1.0

Document ID: B45024, Revision A - Build 55241

Manual (original)

This is no translation but the original Technical Manual in English.

Designed in Germany and Poland, manufactured in Poland.

Woodward GmbH

Handwerkstr. 29

70565 Stuttgart

Germany

Telephone: +49 (0) 711 789 54-510

Fax: +49 (0) 711 789 54-101

E-mail: industrial.support@woodward.com

Internet: <https://www.woodward.com>

© 2025 Woodward GmbH. All rights reserved.

Brief Overview

The IKD2M-8/8 is an expansion module which has 8 digital input and 8 digital output channels. The input port status of the IKD2M-8/8 are transmitted to the PLC or upper level control unit for processing via CAN bus port. An upper level control unit is for example an easYgen-3000XT, LS-6XT, GC-3000XT or DTSC-200A. The status of the relay outputs is controlled by the superior device. Several IKD2M-8/8 devices can be connected to one upper level control unit. For the maximum number of devices see Product Specification #45033 at <http://wwdmanuals.com/ikd2m>.

Scope of delivery

The following parts are included in the scope of delivery. Please check prior to the installation that all parts are present.

- Device IKD2M-8/8 module. All screwable terminal connectors are delivered with plug and jack.



The latest versions of the Technical Manual are available at the Woodward web site.

QR Code

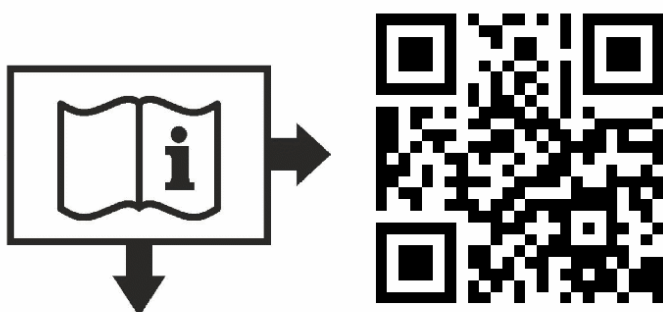

<http://wwdmanuals.com/ikd2m>

To get access to the complete product documentation, scan this QR code or use the following link: <http://wwdmanuals.com/ikd2m>.

Sample application setup

A typical application for the module is to extend the digital inputs of an easYgen-3000XT.

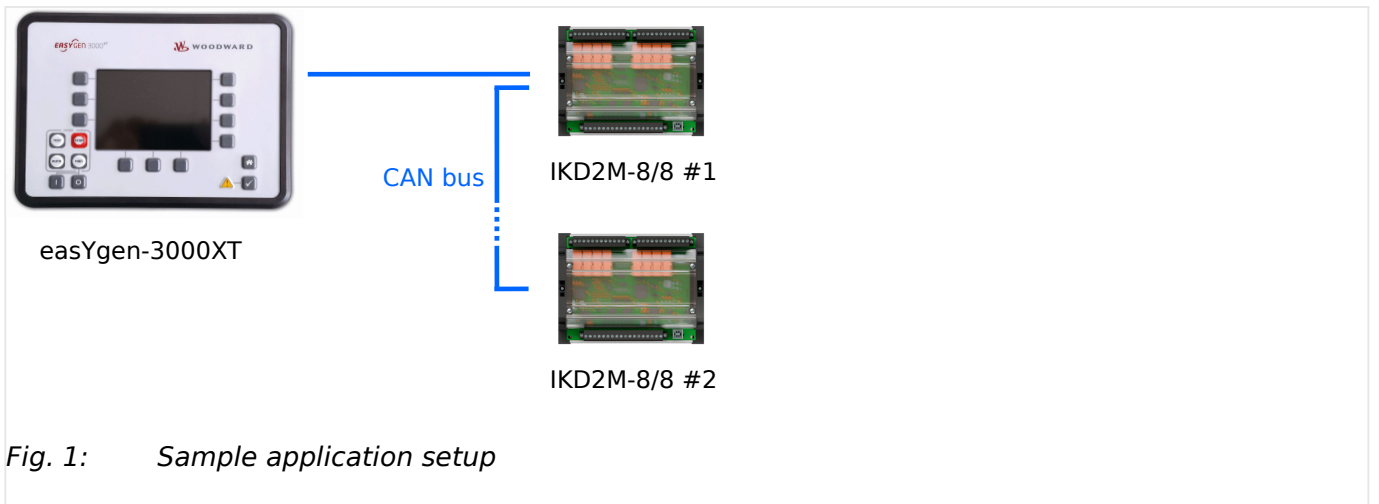

Table of Contents

1	General Information	7
1.1	Revision History Of This Technical Manual	7
1.2	Depiction of Notes and Instructions	7
1.2.1	Copyright And Disclaimer	9
1.2.2	Service And Warranty	9
1.3	Safety	10
1.3.1	Personnel	10
1.3.2	General Safety Notes	11
1.3.3	Protective Equipment And Tools	13
1.3.4	Intended Use	14
2	System Overview	15
2.1	LEDs Indicate State	15
3	Installation	16
3.1	Mount Unit	16
3.2	Setup Connections	16
3.2.1	Terminal Allocation	17
3.2.2	Wiring Diagram	19
3.2.3	Power Supply	20
3.2.4	Discrete Inputs	21
3.2.5	Relays / Digital Outputs	22
3.3	Setup Interfaces	23
3.3.1	USB (2.0 slave) Interface - Service Port	23
3.3.2	CAN Bus Interfaces	24
4	Configuration	28
4.1	Configuration Application	28
4.1.1	Access Via PC (Toolkit)	28
4.1.2	Configure CAN Bus	28
4.1.3	Configure LEDs	31
4.1.4	Configure Relay Outputs	31

4.1.5	Further Parameters	32
5	Operation	33
5.1	Function of LEDs	33
5.2	Function of Discrete Inputs	34
5.3	Function of Relays	34
6	Application Field	36
6.1	Example applications with easYgen-3000XT	36
7	Interfaces And Protocols	38
7.1	CAN Interface	38
8	Technical Specifications	39
8.1	Technical Data	39
8.1.1	Ambient Variables	39
8.1.2	Inputs	40
8.1.3	Outputs	40
8.1.4	Interfaces	41
8.1.5	Housing	41
8.1.6	Approvals	41
8.2	Environmental Data	42
9	Appendix	44
9.1	CAN Messages	44
9.1.1	Send Messages	44
9.1.2	Receive Messages	45
9.1.3	Start/Stop Message	46
10	Third Party Software	47
11	List Of Abbreviations	48
12	Index	49

1 General Information

1.1 Revision History Of This Technical Manual

Rev.	Date	Editor	Changes
A	2025-11	MK	Technical Manual - 1st release <ul style="list-style-type: none">• Describing device software release 1.0



Up to date documentation?

Please check Woodward web site for latest revision of this Technical Manual (search for: "B45024") and if there is an Errata Sheet with latest information.

1.2 Depiction of Notes and Instructions

Safety Instructions

Safety instructions are marked with symbols in these instructions. The safety instructions are always introduced by signal words that express the extent of the danger.

DANGER!



This combination of symbol and signal word indicates an immediately-dangerous situation that could cause death or severe injuries if not avoided.

WARNING!



This combination of symbol and signal word indicates a possibly-dangerous situation that could cause death or severe injuries if it is not avoided.

CAUTION!



This combination of symbol and signal word indicates a possibly-dangerous situation that could cause slight injuries if it is not avoided.

NOTICE!



This combination of symbol and signal word indicates a possibly-dangerous situation that could cause property and environmental damage if it is not avoided.

Tips and Recommendations



This symbol indicates useful tips and recommendations as well as information for efficient and trouble-free operation.

Consignes de sécurité

Les consignes de sécurité sont signalées par des symboles dans les présentes instructions. Les consignes de sécurité sont toujours introduites par des mots de signalisation qui expriment l'ampleur du danger.

DANGER!



Cette combinaison de symbole et de mot de signalisation indique une situation immédiatement dangereuse qui pourrait entraîner la mort ou des blessures graves si elle n'est pas évitée.

WARNING!



Cette combinaison de symbole et de mot de signalisation indique une situation potentiellement dangereuse qui peut entraîner la mort ou des blessures graves si elle n'est pas évitée.

CAUTION!



Cette combinaison de symbole et de mot de signalisation indique une situation potentiellement dangereuse qui peut entraîner des blessures légères si elle n'est pas évitée.

NOTICE!



Cette combinaison de symbole et de mot de signalisation indique une situation potentiellement dangereuse qui pourrait causer des dommages matériels et environnementaux si elle n'est pas évitée.

Conseils et recommandations



Ce symbole indique des conseils et des recommandations utiles ainsi que des informations pour un fonctionnement efficace et sans problème.

Dimensions



Dimensions in Figures

All dimensions shown are in **mm**, unless specified otherwise.

1.2.1 Copyright And Disclaimer

Disclaimer

All information and instructions in this manual have been provided under due consideration of applicable guidelines and regulations, the current and known state of the art, as well as our many years of in-house experience. Woodward assumes no liability for any damages due to:

- Failure to comply with the instructions in this manual
- Improper use / misuse
- Willful operation by non-authorized persons
- Unauthorized conversions or non-approved technical modifications
- Use of non-approved spare parts

The originator is solely liable for the full extent for damages caused by such conduct. The obligations agreed-upon in the delivery contract, the general terms and conditions, the manufacturer's delivery conditions, and the statutory regulations valid at the time the contract was concluded, apply.

Copyright

This manual is protected by copyright. No part of this manual may be reproduced in any form or incorporated into any information retrieval system without written permission of Woodward GmbH.

Delivery of this manual to third parties, duplication in any form - including excerpts - as well as exploitation and/or communication of the content, are not permitted without a written declaration of release by Woodward GmbH.

Actions to the contrary will entitle us to claim compensation for damages. We expressly reserve the right to raise any further accessory claims.

1.2.2 Service And Warranty

Our Customer Service is available for technical information.

For regional support, please refer to: ⇒ http://www.woodward.com/Support_pgd.aspx.

In addition, our employees are constantly interested in new information and experiences that arise from usage and could be valuable for the improvement of our products.

Warranty terms



Please enquire about the terms of warranty from your nearest Woodward representative.

For our contact search webpage please go to: ⇒ <http://www.woodward.com/Directory.aspx>

1.3 Safety

NOTICE!



Damage due to improper use!

Improper use of the device may cause damage to the device as well as connected components.

Improper use includes, but is not limited to:

- Storage, transport, and operation outside the specified conditions.

1.3.1 Personnel

WARNING!



Hazards due to insufficiently qualified personnel!

If unqualified personnel perform work on or with the control unit hazards may arise which can cause serious injury and substantial damage to property.

- Therefore, all work must only be carried out by appropriately qualified personnel.

This manual specifies the personnel qualifications required for the different areas of work, listed below:

Personnel:

- **Qualified electrician**

The qualified electrician is able to execute tasks on electrical equipment and independently detect and avoid any possible dangers due to his training, expertise and experience, as well as knowledge of all applicable regulations.

The qualified electrician has been specially trained for the work environment in where he is active and familiar with all relevant standards and regulations.

- **User**

The user operates the device within the limits of its intended use, without additional previous knowledge but according to the instructions and safety notes in this manual.

The workforce must only consist of persons who can be expected to carry out their work reliably. Persons with impaired reactions due to, for example, the consumption of drugs, alcohol, or medication are prohibited.

When selecting personnel, the age-related and occupation-related regulations governing the usage location must be observed.

1.3.2 General Safety Notes

Electrical hazards

DANGER!



Life-threatening hazard from electric shock!

There is an imminent life-threatening hazard from electric shocks from live parts. Damage to insulation or to specific components can pose a life-threatening hazard.

- Only a qualified electrician should perform work on the electrical equipment.
- Immediately switch off the power supply and have it repaired if there is damage to the insulation.
- Before beginning work at live parts of electrical systems and resources, cut the electricity and ensure it remains off for the duration of the work. Comply with the five safety rules in the process:
 - cut electricity;
 - safeguard against restart;
 - ensure electricity is not flowing;
 - earth and short-circuit; and
 - cover or shield neighboring live parts.
- Never bypass a fuse or render it inoperable. Always use the correct amperage when changing a fuse.
- For critical functions we recommend the usage of the on board digital inputs (e.g. of the easYgen-3000XT).
- Keep moisture away from live parts. Moisture can cause short circuits.

Prime mover safety

WARNING!



Hazards due to insufficient prime mover protection

The engine, turbine, or other type of prime mover should be equipped with an overspeed (over-temperature, or over-pressure, where applicable) shutdown device(s), that operates totally independently of the prime mover control device(s) to protect against runaway or damage to the engine, turbine, or other type of prime mover with possible personal injury or loss of life should the mechanical-hydraulic governor(s) or electric control(s), the actuator(s), fuel control(s), the driving mechanism(s), the linkage(s), or the controlled device(s) fail.

Modifications

WARNING!



Hazards due to unauthorized modifications

Any unauthorized modifications to or use of this equipment outside its specified mechanical, electrical, or other operating limits may cause personal injury and/or property damage, including damage to the equipment.

Any unauthorized modifications:

- constitute "misuse" and/or "negligence" within the meaning of the product warranty thereby excluding warranty coverage for any resulting damage
- invalidate product certifications or listings.

Use of batteries/alternators

NOTICE!



Damage to the control system due to improper handling

Disconnecting a battery from a control system that uses an alternator or battery-charging device whilst the charging device is still connected causes damage to the control system.

- Make sure the charging device is turned off before disconnecting the battery from the system.

Electrostatic discharge



- Protective equipment: ESD wrist band

NOTICE!



Damage from electrostatic discharge

All electronic equipment sensitive to damage from electrostatic discharge, which can cause the control unit to malfunction or fail.

- To protect electronic components from static damage, take the precautions listed below.

1. ▷ Avoid build-up of static electricity on your body by not wearing clothing made of synthetic materials. Wear cotton or cotton-blend materials as much as possible because these do not store static electric charges as easily as synthetics.

2. ▷  Before working on terminals on the control unit, ground yourself by touching and holding a grounded metal object (pipes, cabinets, equipment, etc.) to discharge any static electricity.
Alternatively wear an ESD wrist band connected to ground.

3. ▷



Before any maintenance work on the control unit, ground yourself by touching and holding a grounded metal object (pipes, cabinets, equipment, etc.) to discharge any static electricity.
Alternatively wear an ESD wrist band connected to ground.

4. ▷

Keep plastic, vinyl, and Styrofoam materials (such as plastic or Styrofoam cups, cigarette packages, cellophane wrappers, vinyl books or folders, plastic bottles, etc.) away from the control unit, modules and work area.

5. ▷

Opening the control cover may void the unit warranty. Do not remove the printed circuit board (PCB) from the control cabinet unless instructed by this manual.



If instructed by this manual to remove the PCB from the control cabinet, follow these precautions:

- Ensure that the device is completely voltage-free (all connectors have to be disconnected).
- Do not touch any part of the PCB except the edges.
- Do not touch the electrical conductors, connectors, or components with conductive devices or with bare hands.
- When replacing a PCB, keep the new PCB in the plastic antistatic protective bag it comes in until you are ready to install it. Immediately after removing the old PCB from the control cabinet, place it in the antistatic protective bag.



For additional information on how to prevent damage to electronic components caused by improper handling, read and observe the precautions in:

- "Woodward manual 82715, Guide for Handling and Protection of Electronic Controls, Printed Circuit Boards, and Modules".

1.3.3 Protective Equipment And Tools

Protective gear

Personal protective equipment serves to protect risks to the safety and health of persons as well as to protect delicate components during work.

Certain tasks presented in this manual require the personnel to wear protective equipment. Specific required equipment is listed in each individual set of instructions.

The cumulative required personal protective equipment is detailed below:

Protective equipment: ESD wrist band

The ESD (**e**lectro**s**tatic **d**ischarge) wrist band keeps the user's body set to ground potential. This measure protects sensitive electronic components from damage due to electrostatic discharge.

Tools

Use of the proper tools ensures successful and safe execution of tasks presented in this manual.

Specific required tools are listed in each individual set of instructions.

The cumulative required tools are detailed below:

1.3.4 Intended Use

This control unit has been designed and constructed solely for the intended use described in this manual.

The IKD2M-8/8 devices are designed to be installed on the back panel of a switch gear cabinet. The terminals are always located on the inner side of the housing.

This control unit must be used exclusively as extension of upper level control units.

- Intended use requires operation of the control unit within the specifications listed in [8.1 Technical Data](#).
- Intended use also includes compliance with all instructions and safety notes presented in this manual.
- Any use which exceeds or differs from the intended use shall be considered improper use!
- No claims of any kind for damage will be entertained if such claims result from improper use.

2 System Overview

2.1 LEDs Indicate State

The IKD2M-8/8 indicates the state of the device and the digital inputs and outputs via LEDs.

LED	Function
LED A: Operation	Device operation (CPU ok)
LED B: CAN communication	Off: no CAN communication Flashing: CAN communication normal, data is received.
LED C: Alarm	Off: no CAN bus alarm On: CAN bus alarm is active: no data is received and the CAN error delay time has expired.
LEDs DI: Status DI 01 .. 08	When DI 01 .. 08 input is active, corresponding DI 01 .. 08 LED is illuminated.
LEDs DO: Status DO 01 .. 08	When DO 01 .. 08 output is active, corresponding DO 01 .. 08 LED is illuminated.

Arrangement of the LEDs:

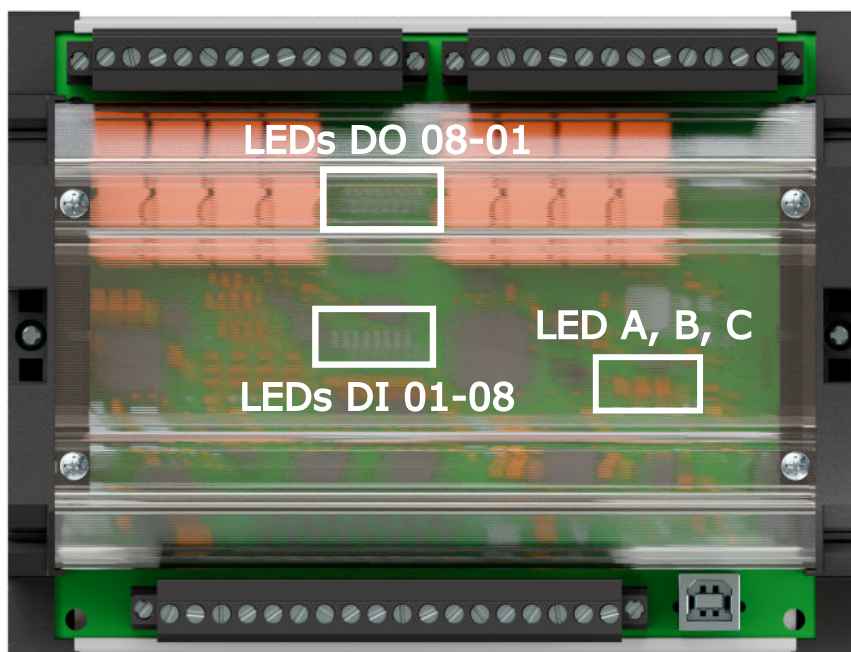

Fig. 2: Location of the LEDs

3 Installation

3.1 Mount Unit

The IKD2M-8/8 is a unit for DIN-rail/rear panel mounting.

Dimensions

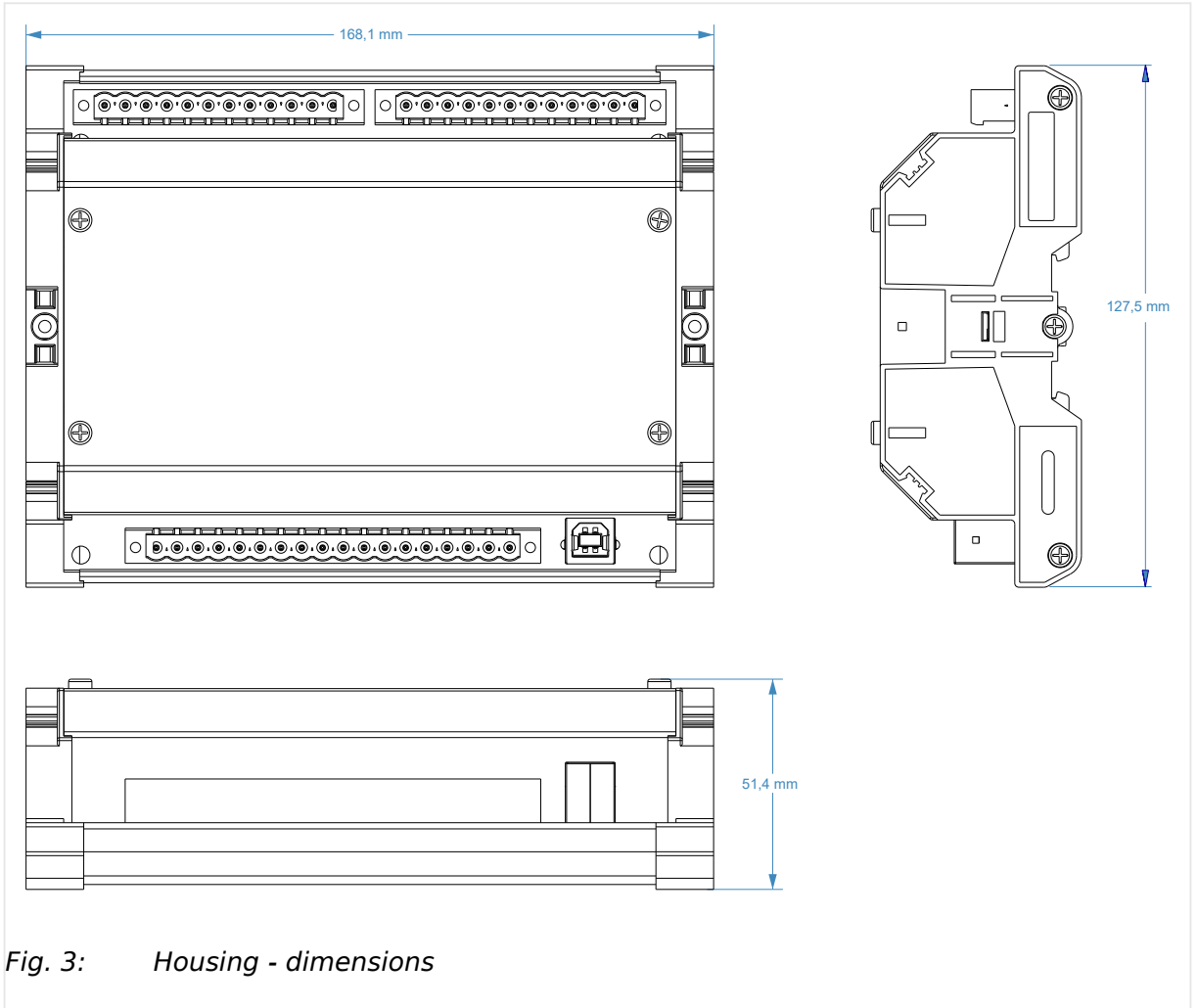

3.2 Setup Connections

NOTICE!



Avoid electrostatic discharge!

Before working with terminals please read and follow the instructions of chapter [↗](#) "Electrostatic discharge".

For CAN shielded cabling, no more than 25 mm wiring exposed without shield coverage are allowed at terminal plug side.

General notes

NOTICE!



Malfunctions due to literal use of example values

All technical data and ratings indicated in this chapter are merely listed as examples. Literal use of these values does not take into account all actual specifications of the control unit as delivered.

- For definite values please refer to chapter  "8.1 Technical Data".

Wire sizes



Field wiring shall be made with use of cables which have temperature rating not less than 90 °C.

AWG	mm ²	AWG	mm ²	AWG	mm ²	AWG	mm ²	AWG	mm ²	AWG	mm ²
30	0.05	21	0.38	14	2.5	4	25	3/0	95	600MCM	300
28	0.08	20	0.5	12	4	2	35	4/0	120	750MCM	400
26	0.14	18	0.75	10	6	1	50	300MCM	150	1000MCM	500
24	0.25	17	1.0	8	10	1/0	55	350MCM	185		
22	0.34	16	1.5	6	16	2/0	70	500MCM	240		

Table 1: Conversion chart - wire sizes

3.2.1 Terminal Allocation

The device terminals are allocated as follows:

The max. possible conductor cross-section of the terminals used is $A_{\max} = 2.5 \text{ mm}^2$!

3 Installation

3.2.1 Terminal Allocation

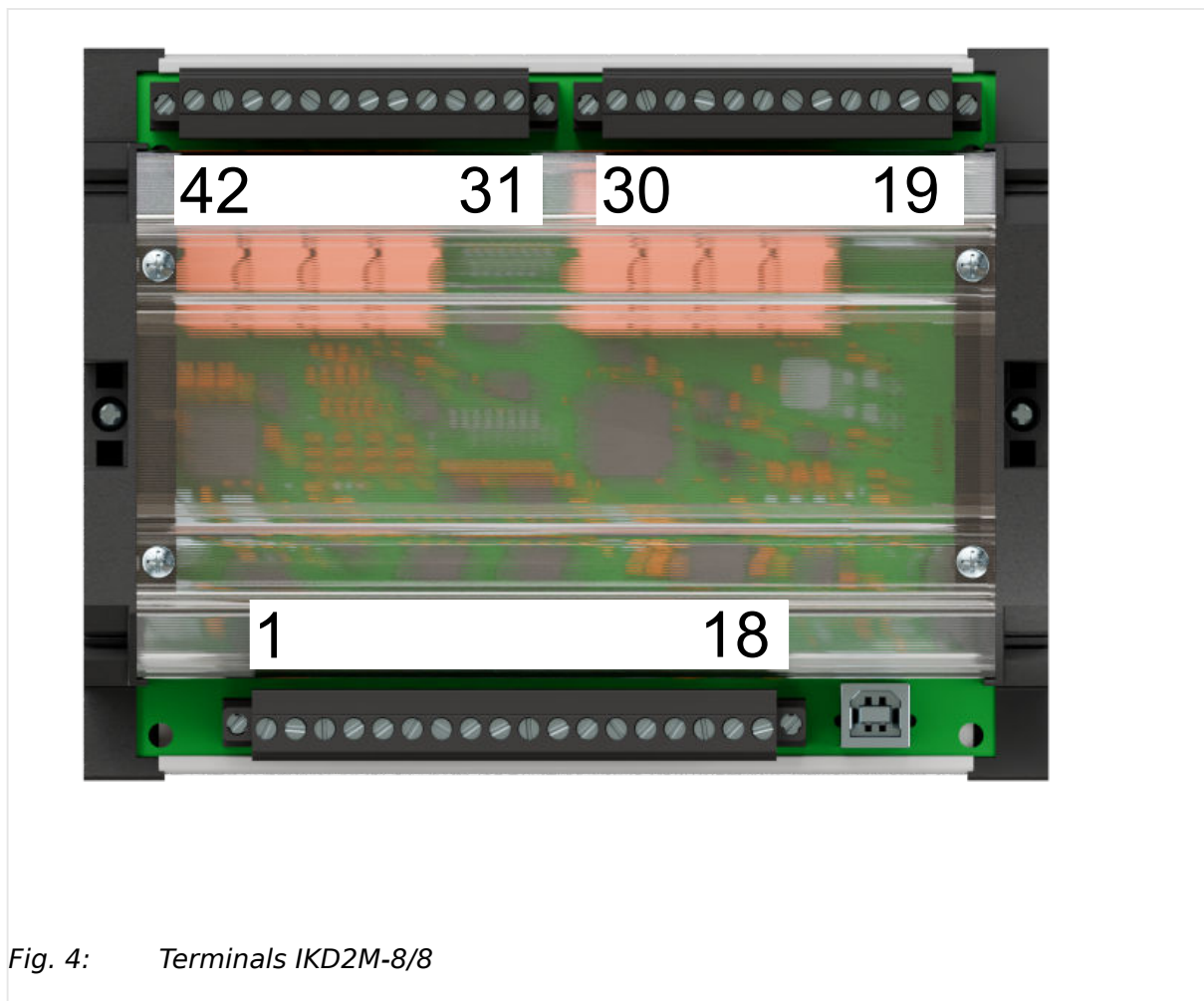
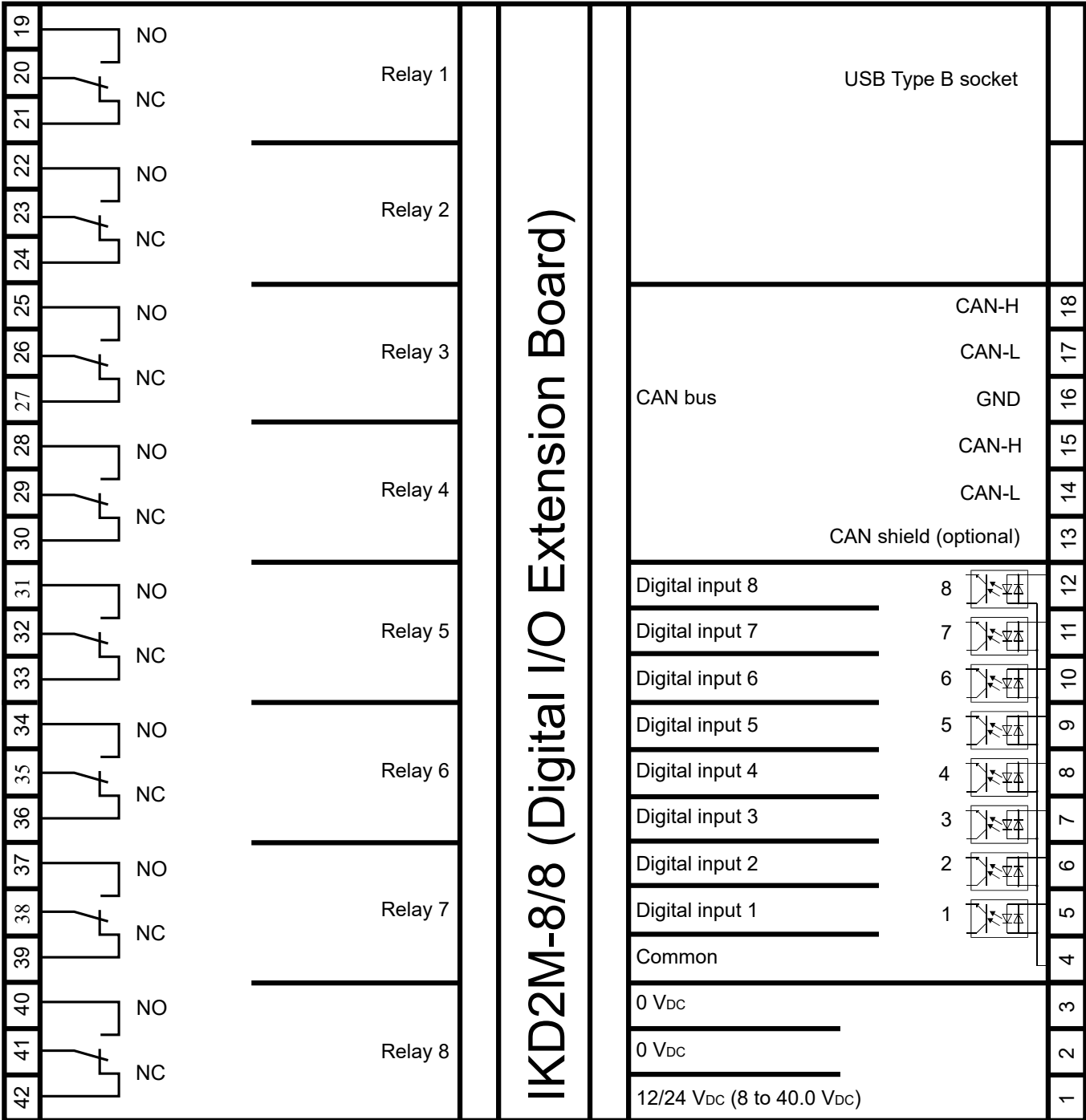

Fig. 4: Terminals IKD2M-8/8

3.2.2 Wiring Diagram



Subject to technical modifications

IKD2M-8/8 Wiring Diagram

Fig. 5: Wiring Diagram



General recommendations

Ensure appropriate cable cross sections following the local standards and restrictions.

The maximum cable cross section of the terminal blocks is 2.5 mm².

For every type of signal lines like power supply, DI:

- Return line has to be close to forward signal line.
- Use cables instead of single wires.
 - In case of using single wires please do at least one twist per meter to keep wires together closely.

3.2.3 Power Supply

General notes

WARNING!



Risk of electric shock - plastic housing

- The conductor providing the connection must have a wire larger than or equal to 2.5 mm² (14 AWG). The connection must be performed properly.



Woodward strictly recommends to use a power supply that is fulfilling the SELV restrictions (SELV = separated or safety extra-low voltage, see IEC)



Woodward recommends to use one of the following slow-acting protective devices in the supply line to terminal 1:

- Fuse NEOZED D01 6A or equivalent **or**
- Miniature Circuit Breaker 6A / Type C

(for example: ABB type: S271C6 or equivalent)



Power ON

With power ON the IKD2M-8/8 device LED 'Operation' shows the device is working.

Schematic and terminals

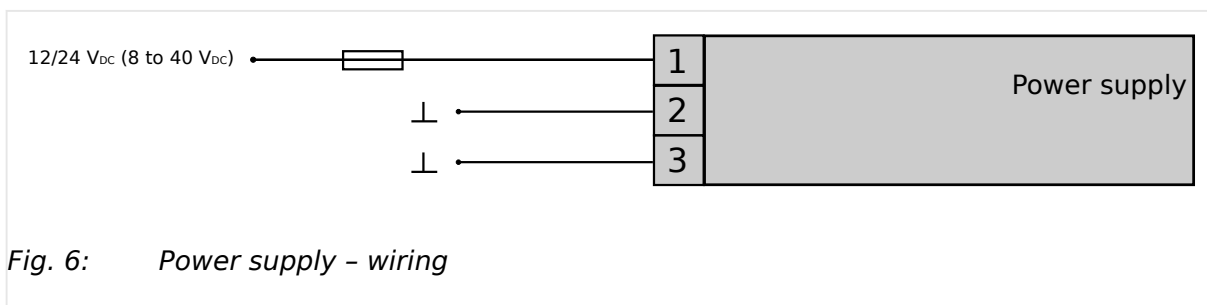

Terminal	Description
1	B+ / 12/24 V _{DC} (8 to 40.0 V _{DC})
2	B- / 0 V _{DC}
3	B- / 0 V _{DC}

Table 2: Power supply - terminal assignment

Only one of the two ground terminals needs to be connected.

3.2.4 Discrete Inputs

CAUTION!



Please note that the maximum voltages which may be applied at the discrete inputs are defined as follows. Voltages higher than those specified destroy the hardware!

Maximum input range: ± 8 to 40 V_{DC}.



Activate digital input

The reference potential for the discrete inputs must be connected to Common (terminal 4).

Schematic and terminal assignment

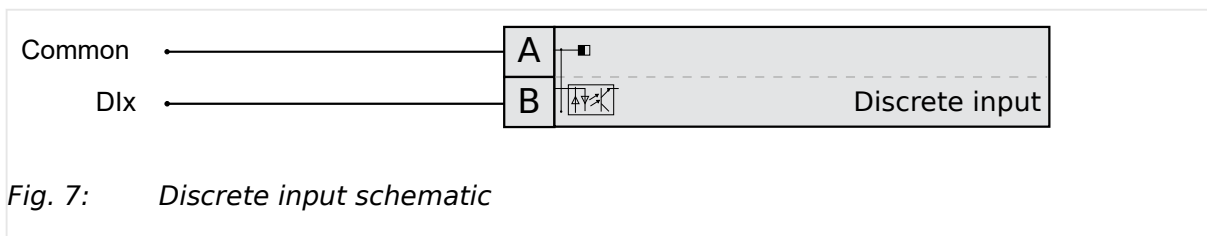

Terminal	Description	A max.	
A	B		
4	5	DI 01	2.5 mm ²
GND	6	DI 02	2.5 mm ²

Terminal		Description	A max.
A	B		
Common ground	7	DI 03	2.5 mm ²
	8	DI 04	2.5 mm ²
	9	DI 05	2.5 mm ²
	10	DI 06	2.5 mm ²
	11	DI 07	2.5 mm ²
	12	DI 08	2.5 mm ²

Table 3: Discrete inputs - terminal assignment

Avoid electrostatic discharge during cable connection to the unit.

3.2.5 Relays / Digital Outputs

Schematic and terminals

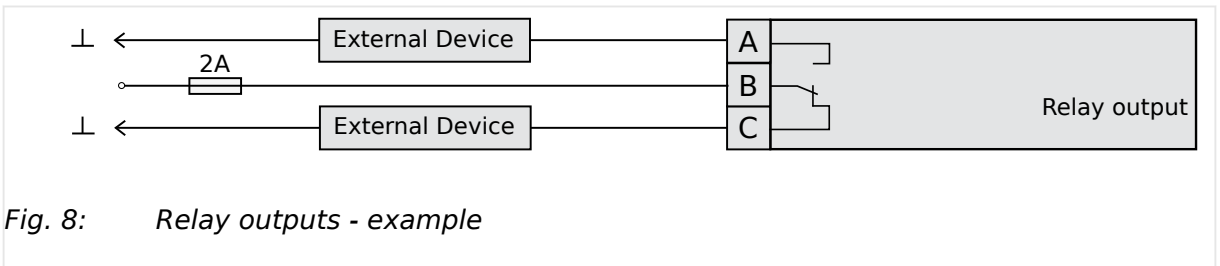

Fig. 8: Relay outputs - example

Terminal			Description
A	B	C	
N.O.	Root	N.C.	
19	20	21	Relay 01
22	23	24	Relay 02
25	26	27	Relay 03
28	29	30	Relay 04
31	32	33	Relay 05
34	35	36	Relay 06
37	38	39	Relay 07
40	41	42	Relay 08

Table 4: Relay outputs - terminal assignment

Avoid electrostatic discharge during cable connection to the unit.

Usage as FUEL and GAS VALVE



The NO contact of relay output 2-8 can be used as FUEL and GAS VALVE coupling relay according to UL/ULC 6200:2019 with the defined VA-rating, [↪ "Relay outputs 'DO xx'"](#).

For this function the following prerequisites are mandatory:

- Relay 1 must be connected in series to the relay outputs used for FUEL and GAS VALVE coupling relay (see figure below [↪ Fig. 9](#))
- Parameter "Keep relay states at timeout" should be set to "No" (parameter [↪ 119](#))

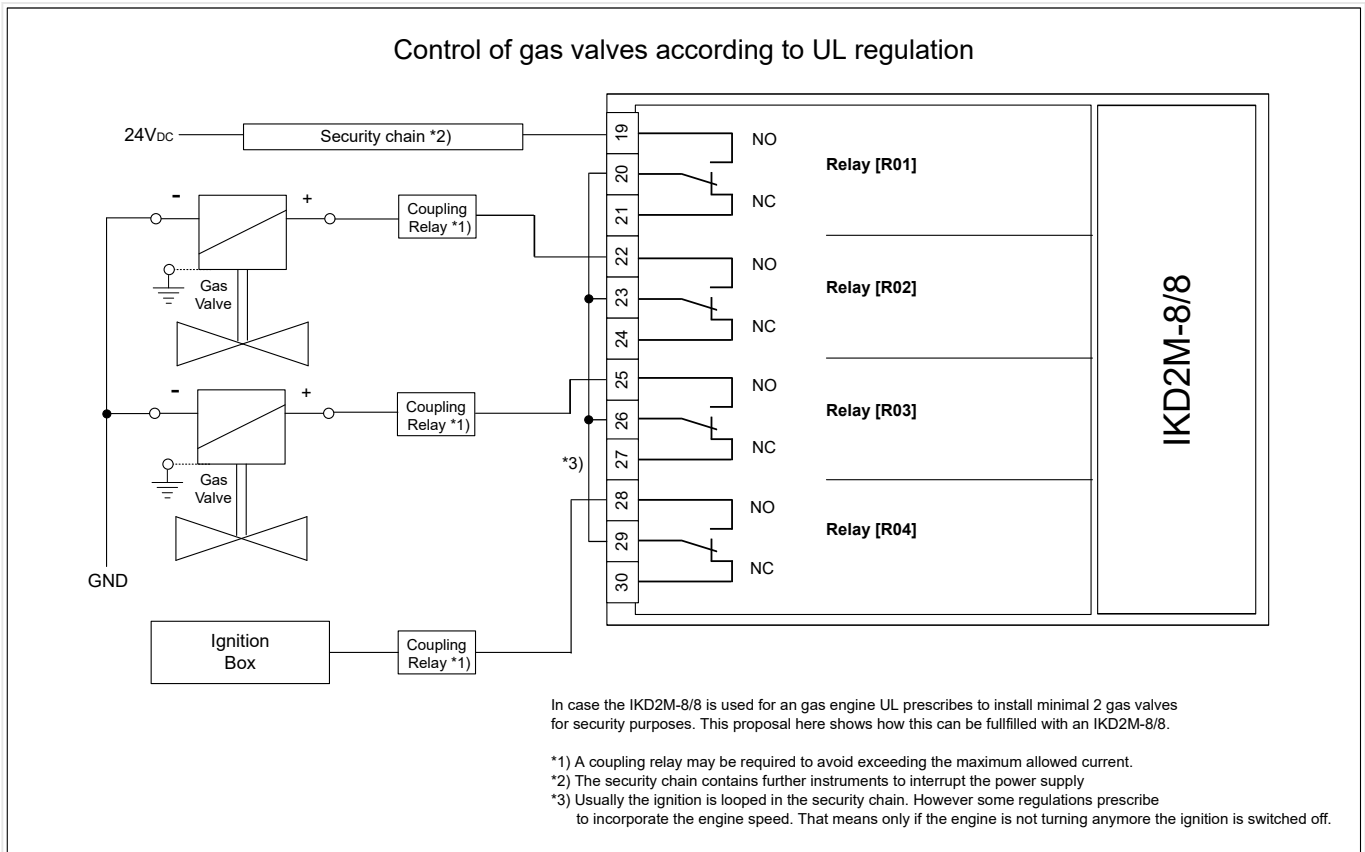

Fig. 9: Control of gas valves according to UL regulation

3.3 Setup Interfaces

3.3.1 USB (2.0 slave) Interface - Service Port

General notes

WARNING!



USB is a service port only and cannot be permanently connected during normal operation. It is dedicated for service activities only.



Avoid electrostatic discharge!

Avoid electrostatic discharge during USB cable connection to the unit.



To connect this USB 2.0 (slave) device a USB cable with USB Type A (PC/laptop side) and Type B (Woodward device side) connectors is necessary.

USB cable length shall be limited up to 3 m. It is recommended to use professional (high quality) USB cable: 28AWG/1P+24AWG/2C with good shielding.



Use USB service port for ToolKit connection

The USB interface is a service port and the preferred ToolKit connection!

'Read only' USB interface

For location see [↪ "3.2.1 Terminal Allocation"](#).

For others than ToolKit connection the USB interface is read-only!

It can be used for further service tasks from manufacturer's side.

Connecting it to a PC/laptop will display the USB interface available and all files prepared from Woodward manufacturing side. Read/write attributes of this service port are restricted to read only.

3.3.2 CAN Bus Interfaces

NOTICE!



Avoid electrostatic discharge!

Before working with terminals please read and follow the instructions of chapter [↪ "Electrostatic discharge"](#).

For CAN shielded cabling, no more than 25 mm wiring exposed without shield coverage are allowed at terminal plug side.



Avoid electrostatic discharge!

Avoid electrostatic discharge during CAN cable connection to the unit.

Pin assignment

13	14	15	16	17	18
CAN shield	CAN-L	CAN-H	GND	CAN-L	CAN-H
Interface CAN bus					

Fig. 10: CAN bus - terminals

Terminal	Description	A _{max}
13	CAN shield	1.5 mm ²
14	CAN-L	1.5 mm ²
15	CAN-H	1.5 mm ²
16	GND	1.5 mm ²
17	CAN-L	1.5 mm ²
18	CAN-H	1.5 mm ²

Table 5: CAN bus interface - terminal assignment

CAN-L and CAN-H could be used to loop through CAN bus and/or to connect termination resistance.

Topology

For termination a 120 Ω resistor is recommended to short circuit terminal 14, 15 or terminal 17, 18.

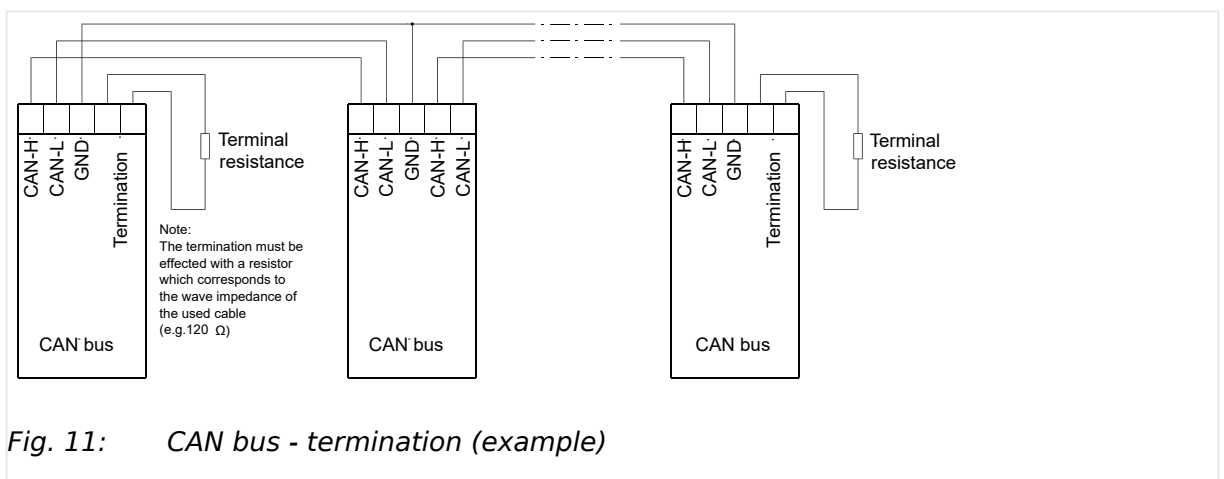

Fig. 11: CAN bus - termination (example)

Maximum CAN bus length

The maximum length of the communication bus wiring is dependent on the configured baud rate. Observe the maximum bus length.

We recommend to use shielded cables.

(Source: CANopen; Holger Zeltwanger (Hrsg.); 2001 VDE VERLAG GMBH, Berlin und Offenbach; ISBN 3-8007-2448-0).

Baud rate	Max. length
1000 kB	25 m
500 kB	100 m
250 kB	200 m
125 kB	250 m

Table 6: CAN bus interface - maximum CAN bus length



Impedance 120 Ohm matching is required at the CAN transceiver to meet the communication quality, and the shielding layer of the shielded wire needs to be grounded.

Cable type

CAN cables with 120 Ohm at 1 MHz shall be used.

Shielding

The CAN shield should be connected to terminal 13.

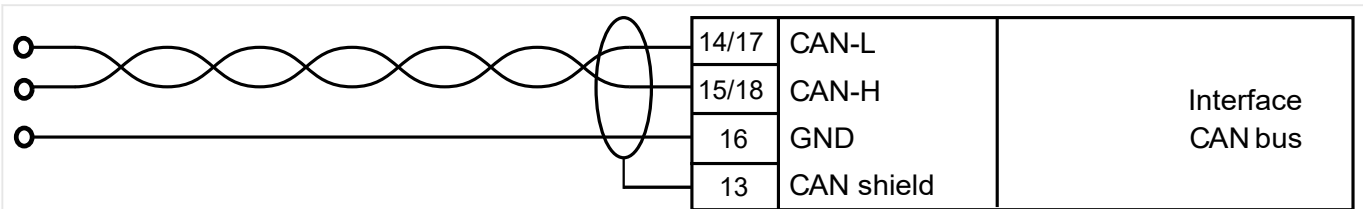

Fig. 12: Shielding CAN bus - connected to terminal

If the IKD2M-8/8 is used as a one-to-one replacement of the IKD1M, the CAN shield can be connected at terminal 13 or as shown in the figure below:

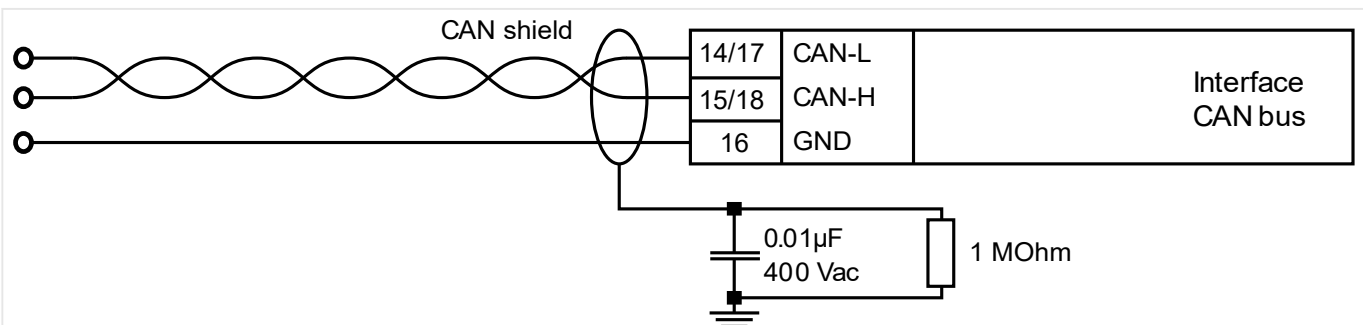

Fig. 13: Shielding CAN bus - grounded (replacement of IKD1M)

Troubleshooting



If there is no data transmission on the CAN bus, check for the following common CAN bus communication problems:

- A T-structure bus is utilized
- CAN-L and CAN-H are switched
- Not all devices on the bus are using identical baud rates
- Termination resistor(s) are missing
- The configured baud rate is too high for wiring length
- The CAN bus cable is routed in close proximity with power cables



Woodward recommends the use of shielded, twisted-pair cables for the CAN bus (see examples).

- Lappkabel Unitronic Bus CAN UL/CSA
- UNITRONIC-Bus LD 2×2×0.22

4 Configuration

4.1 Configuration Application

4.1.1 Access Via PC (Toolkit)

Version



Woodward’s ToolKit software is required to access the unit via PC

- Required version: 7.4 or higher
- Please use the latest available version!
- To obtain the latest version scan this QR code or use the following link: https://wss.woodward.com/manuals/PGC/SW_Tools/ToolKit.



After having the ToolKit software installed, the IKD2M-8/8 device related installer file *.msi should be executed. It installs the *.wstool. This is a device specific file that is tailored to the device. It includes all configuration parameters and visualization values.

4.1.2 Configure CAN Bus

ID	Parameter	Setting range [Default]	Description
123	IKD type	None	The CAN-IDs for sending and receiving data have to be defined by the following parameters: ↩ 102 and ↩ 103
		[IKD-1]	The IKD2M-8/8 is configured as device 1. The CAN-IDs for sending and receiving data are fix: CAN-ID for receiving data (parameter ↩ 102): 0x181 CAN-ID for sending data (parameter ↩ 103): 0x201
		IKD-2	The IKD2M-8/8 is configured as device 2. The CAN-IDs for sending and receiving data are fix: CAN-ID for receiving data (parameter ↩ 102): 0x182

ID	Parameter	Setting range [Default]	Description
			CAN-ID for sending data (parameter ↩> 103): 0x202
		IKD-3	The IKD2M-8/8 is configured as device 3. The CAN-IDs for sending and receiving data are fix: CAN-ID for receiving data (parameter ↩> 102): 0x183 CAN-ID for sending data (parameter ↩> 103): 0x203
		IKD-4	The IKD2M-8/8 is configured as device 4. The CAN-IDs for sending and receiving data are fix: CAN-ID for receiving data (parameter ↩> 102): 0x184 CAN-ID for sending data (parameter ↩> 103): 0x204
102	CAN-ID for receiving data	0 .. 2047 [385]	This parameter defines the ID for receiving data. It has to be entered as a decimal number. example: 385d = 0x181
			Notes This parameter is only valid if parameter ↩> 123 is set to "None"
103	CAN-ID for sending data	0 .. 2047 [513]	This parameter defines the ID for sending data. It has to be entered as a decimal number. example: 513d = 0x201
			Notes This parameter is only valid if parameter ↩> 123 is set to "None"
111	CAN error delay	0.00 .. 99.98 s [2.50 s]	This parameter defines the delay time before a CAN error is detected. If the unit did not receive data within this configured limit a CAN fault is recognized. Additionally in Byte 7 of the CAN sending message a fault bit is set. If it is still possible this message can be received by another CAN participant.
			Notes If this parameter is set to "0" a CAN fault does not lead to an alarm.
			Notes

ID	Parameter	Setting range [Default]	Description
			<p>Setting this time below the sending rate of the corresponding unit would lead to permanently triggering CAN error.</p> <p>It is recommended to set a value that is at least twice the sending rate of the external sender.</p>
106	CAN baud rate	125 / 250 / 500 / 1000 kBd [250 kBd]	<p>This parameter defines the used baud rate.</p> <p>Notes</p> <p>Please note that all participants on the CAN bus must use the same baud rate.</p>
109	Rate of sending	0.00 .. 99.98 s [0.10 s]	<p>This parameter defines the send rate.</p> <p>Notes</p> <p>If this parameter is set to "0" the device does not send anything.</p>
101	CAN node ID	0 to 31 [1]	<p>Node ID of the device.</p> <p>Only for remote start/stop.</p> <p>Notes</p> <p>For details see (↪ "9.1.3 Start/Stop Message")</p>
110	Activate remote start/stop	[No]	No reaction to remote start/stop message.
		Yes	<p>Reaction to remote start/stop message.</p> <p>For details see (↪ "9.1.3 Start/Stop Message")</p> <p>Notes</p> <p>Please note that the Node-Id has to match.</p>
127	Start/Stop mode	[Auto Start]	<p>Data transmission is started automatically after power up of the device.</p> <p>Transmission can be stopped remotely.</p>
		Stopped	<p>Data transmission is not started after power up of the device.</p> <p>Data transmission has to be started remotely via a start message.</p> <p>Transmission can be stopped remotely.</p> <p>For details see (↪ "9.1.3 Start/Stop Message")</p>

ID	Parameter	Setting range [Default]	Description
114	Set default values	[No]	The restoring of the configured parameters to factory default values is not enabled.
		Yes	All parameters will be restored to factory default values. After default set this parameter will be automatically set to No.

4.1.3 Configure LEDs

ID	Parameter	Setting range [Default]	Description
124	LED A: Operation	Off / Red / Green / Orange [Green]	Color of LED A - device in operation
125	LED B: CAN communication	Off / Red / Green / Orange [Orange]	Color of LED B - status CAN communication: LED is blinking each time when data is received via CAN bus.
126	LED C: Alarm	Off / Red / Green / Orange [Red]	Color of LED C - alarm status: LED is illuminated when no data is received via CAN bus and the CAN error delay time has expired.

4.1.4 Configure Relay Outputs



Usage of relay outputs as FUEL and GAS VALVE coupling relay according to UL/ULC 6200:2019

Incorporate relay 1 for safety reason, see [↪](#) "Usage as FUEL and GAS VALVE".

For this function the parameter "Keep relay states at timeout" must be set to "No" (parameter [↪](#) 119).

ID	Parameter	Setting range [Default]	Description
119	Keep relay states at timeout	[No]	At a CAN bus timeout all relays (except relay 1 if configured as self test) will be de-energized. This setting is mandatory when using relay outputs as FUEL and GAS VALVE coupling relay according to UL/ULC 6200:2019.
		Yes	At a CAN bus timeout the state of the relays will be kept as they are.

ID	Parameter	Setting range [Default]	Description
120	Relay 1 as self test	[No]	Relay 1 is energized or de-energized by an upper level control unit or PLC. Additionally it will be de-energized when there is a CPU failure.
		Yes	Relay 1 is only used as hardware self test relay: The relay is energized as long as the IKD2M-8/8 is operational. It will be de-energized when there is a CPU failure. In this mode neither an upper level control unit nor a PLC can influence it.

4.1.5 Further Parameters



The following parameters are visible in the Offline mode and are for internal use only: ID 222, 333, 444.

5 Operation

5.1 Function of LEDs

The LEDs indicate the status of the module.

LED A: Readiness for operation

The LED is activated if the device is in operation (the CPU is ok).

Default color: GREEN

The color can be configured with "LED A: Operation" (parameter [↔ 124](#))

LED B: CAN bus communication

The LED flashes if the CAN bus communication is working correctly. For fast send rates the flashing seems like permanent on.

It stops flashing when no CAN message is received.

Default color: ORANGE

The color can be configured with "LED B: CAN communication" (parameter [↔ 125](#))

LED C: Alarm status

The LED indicates a CAN bus alarm. It is activated when no CAN messages are received for the configured CAN delay time (parameter [↔ 111](#)).

Default color: RED

The color can be configured with "LED C: Alarm" (parameter [↔ 126](#))

LEDs DI 01 - 08

One IKD2M-8/8 has 8 digital inputs. The physical status of each digital input is represented by one LED. If an input is set to a high level, the corresponding LED is activated.

Color: YELLOW

LEDs DO 01 - 08

One IKD2M-8/8 has 8 digital outputs. The physical status of each relay output is represented by one LED. If an output energized, the corresponding LED is activated.

Color: YELLOW

CAUTION!



Be aware that the LEDs can change shortly in an undefined way during the boot process of the device.

LEDs are located on the PCBA and are arranged accordingly:

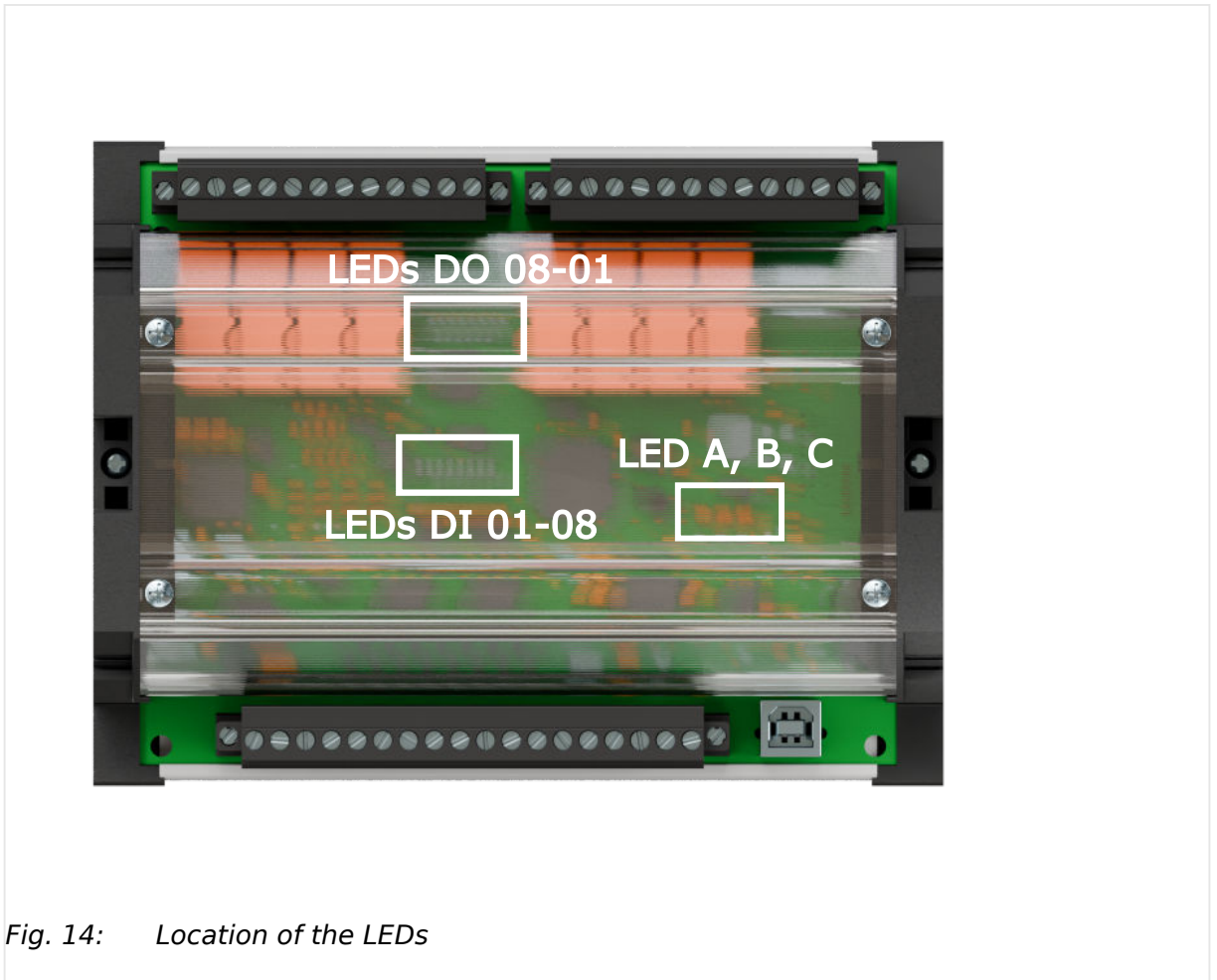



Fig. 14: Location of the LEDs

5.2 Function of Discrete Inputs

The status of the discrete inputs is send via CAN bus to the upper level control unit or PLC. There it is evaluated by the superior device.

 Refer to the technical manual of the upper level control unit eg. easYgen-3000XT, LS6-XT or GC-3000XT for configuration related to each DI.

5.3 Function of Relays

The Relays are controlled by the superior device. Additionally, the status of the discrete outputs is send via CAN bus to the upper level control unit or PLC.

 Refer to the technical manual of the upper level control unit eg. easYgen-3000XT, LS6-XT or GC-3000XT for configuration related to each DO.

CAUTION!



Be aware that the relay state can change shortly in an undefined way during the boot process of the device.

6 Application Field

The IKD2M-8/8 is an expansion module that provides 8 digital inputs and 8 digital outputs. They can be processed by

- a higher level control unit **or**
- a PLC

A higher level control unit is for example an easYgen-3000XT, LS-5, LS-6XT, DTSC-200A, ...

Coupling to a Higher Level Control Unit

Recognition of status transferred via external sensors to the discrete inputs and transfer via the engine CAN bus to the higher level control unit that is coupled with the IKD2. Evaluation is proceeded according to the configured action and additional steps are initiated.

Coupling to a PLC

Recognition of status transferred via external sensors to the discrete inputs and transfer via the engine CAN bus to the PLC that is coupled with the IKD2. Evaluation is proceeded according to the program in the PLC. See Appendix (↳ “9.1 CAN Messages”) for according CAN Telegrams.

6.1 Example applications with easYgen-3000XT

The IKD2M-8/8 is an expansion module. The input port status of the IKD2M-8/8 are transmitted to the upper level controller via CAN bus. The output port status of the IKD2M-8/8 are set according to the message received from the upper level controller via CAN bus. This upper level controller is, for example, an easYgen-3000XT.

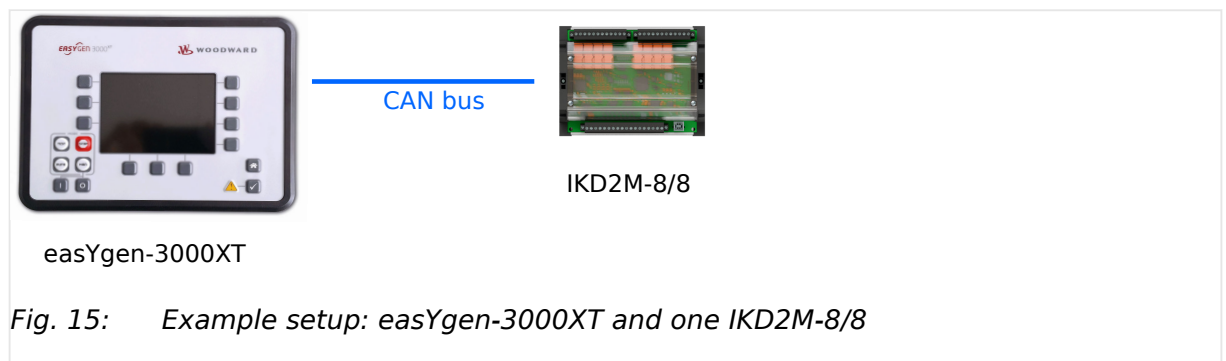
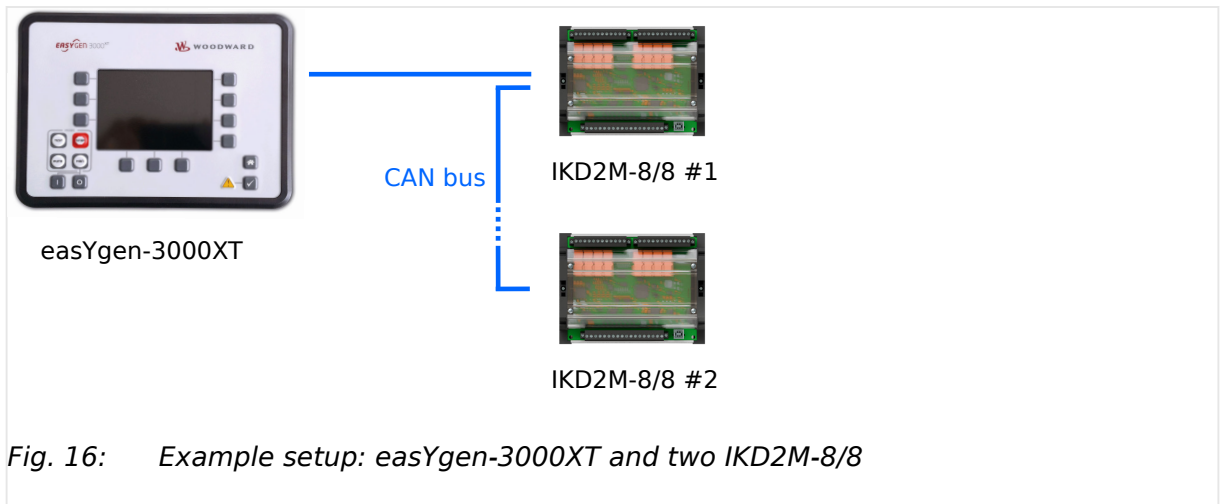

Fig. 15: Example setup: easYgen-3000XT and one IKD2M-8/8



7 Interfaces And Protocols



For interfaces terminal overview refer to [↩➤ “3.3 Setup Interfaces”](#)

7.1 CAN Interface

The IKD2M-8/8 has a CAN bus interface to communicate with an upper level controller e.g. easYgen-3000XT, LS6-XT or GC-3000XT.

Send message

The IKD2M-8/8 sends out a data message at a rate defined by Send rate (parameter [↩➤ 109](#)) at the CAN Send ID (parameter [↩➤ 103](#)).

See Appendix for protocol ([↩➤ “9.1.1 Send Messages”](#)).

Receive message

The IKD2M-8/8 receives at any time a CAN messages at the CAN Receive ID (parameter [↩➤ 102](#)).

See Appendix for protocol ([↩➤ “9.1.2 Receive Messages”](#)).

8 Technical Specifications

8.1 Technical Data

Product label

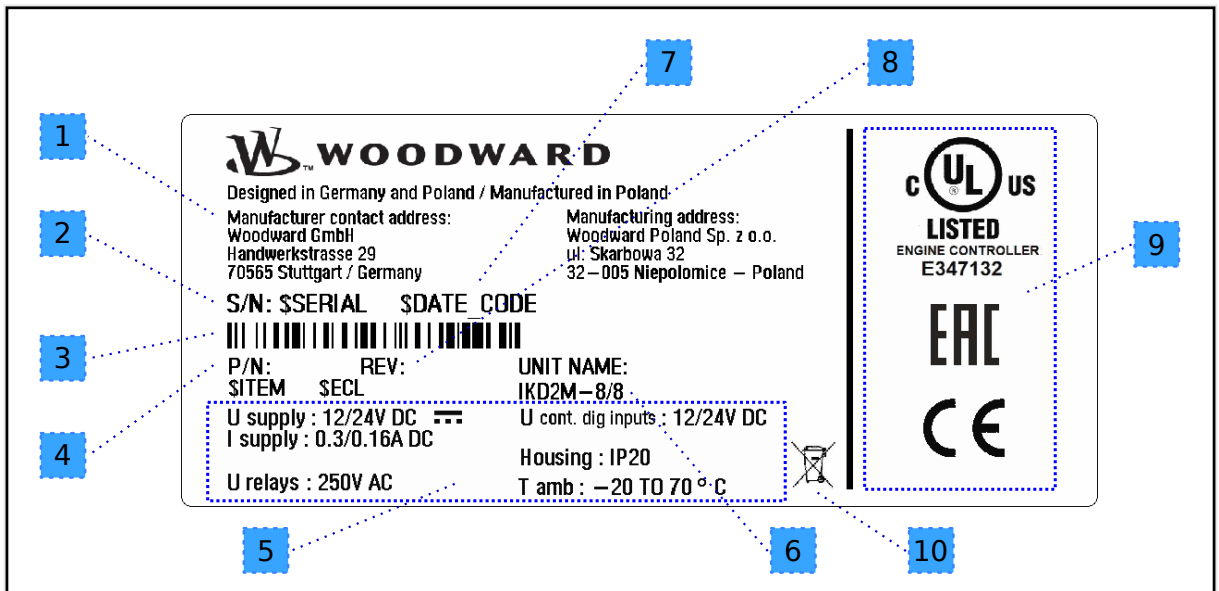

Fig. 17: Product label - the picture is for reference only

Number	Name	Description
1	Address	Manufacturer and manufacturing addresses
2	S/N	Serial number (numerical)
3	S/N	Serial number (barcode)
4	P/N	Item number
5	Details	Technical data
6	Type Description	Description (product name)
7	S/N	Date of production (year-month)
8	REV	Item revision number
9	Approval	Approvals
10	Environment	Separate collection symbol

8.1.1 Ambient Variables

CAUTION!



Device Operating Voltage

Connect the unit only to a DC power source that complies with the safety extra-low voltage (SELV) requirements.

8 Technical Specifications

8.1.2 Inputs

Power supply	12/24 V _{DC} (8 to 40.0 V _{DC}), SELV
Intrinsic consumption	max. 4.5 W
Degree of pollution	2
Maximum elevation	2000 m ASL
Reverse voltage protection (of power supply)	Over the full supply range

8.1.2 Inputs

Discrete inputs 'DI xx'

Discrete inputs	Galvanically isolated
Input range (V _{cont. dig. input})	Rated voltage 12/24 V _{DC} (8 to 40.0 V _{DC})
Input resistance	approx. 40 kOhm
Response time (time from a status change of the digital inputs to the status change of the CAN message)	internal time: 50 ms parameter 109 "Rate of sending" (default value: 100 ms)

8.1.3 Outputs

Relay outputs 'DO xx'

3 pole relays

Discrete/relay outputs	Potential free	Galvanically isolated
Contact material		AgNi
General purpose (GP) (V _{cont, relays})	AC	2.00 A _{AC} @250 V _{AC}
	DC	1.00 A _{DC} @24 V _{DC} VA load, NO contact only Note: NO contact may be used for FUEL and GAS valves according to UL6200:2019 with the defined VA-rating ↳ "Usage as FUEL and GAS VALVE"
		0.36 A _{DC} @125 V _{DC} Not suitable for USA and Canada applications. Not evaluated by UL.
		0.18 A _{DC} @250 V _{DC} Not suitable for USA and Canada applications. Not evaluated by UL.
Pilot Duty	AC	B300
Response time		internal time: 5-16 ms

(time from status change of the CAN message to the status change of the relay)		
--	--	--

8.1.4 Interfaces

USB (slave)

USB 2.0 interface	Galvanically isolated
Type	USB 2.0 standard; slave (Type B)
Data rate	max. 12 Mbit/s
Bus Voltage	5 V
Current consumption	approx. 10 mA

CAN bus interface

CAN bus interface	Galvanically isolated
Insulation voltage (continuously)	100 V _{AC}
Version	CAN bus

8.1.5 Housing

Housing type

Type	Plastic
Dimensions (W × H × D)	168 × 128 × 51 mm
Weight	approx. 430 g
Wiring	Screw-plug-terminals 2.5 mm ²
Recommended locking torque	4 inch pounds / 0.5 Nm. Use 90 °C copper wire or better. Use class 1 wire only or equivalent.

Protection

Ingress protection	IP20
--------------------	------

8.1.6 Approvals

EMC test (CE)	Tested according to applicable EMC standards. Refer to ↗ “8.2 Environmental Data” for details
Listings	CE marking

	UL / cUL Ordinary Locations, File No.: E347132
	EAC

8.2 Environmental Data

Vibration and Shock

Sine vibration test	SV2: Cab or Skid per SAE J1455 Chassis Data 4G, 5 mm, 5-2000 Hz 3 Hour min / axis, 90 min dwells 1 Octave/min
Random vibration test	RV1: Cab or Skid per MIL-STD 202F, M214A, TC(B), SAE J1455 Cab Data 8.2 G 10-2000 Hz 0.04 G ² /Hz 1½ Hrs/axis
Shock test	MS1: per MIL-STD 810F Method 516.5, Procedure 1 40 G Saw tooth pulse, 11 ms

Temperature

Storage temperature	-40 to 85 °C / -40 to 185 °F
Ambient operation temperature	-20 to 70 °C / -4 to 158 °F
Standards	IEC 60068-2-1, Test Ab and Ad
	IEC 60068-2-2, Test Bb and Bd

Humidity

Humidity	H3: per IEC 68-2-30 Test Db 2 Cycles (days) 55 °C 95% RH 12H 20°C Condensing 6H
----------	--

Electromagnetic Compatibility

EN IEC 61000-6-2	2019 - Electromagnetic compatibility (EMC). Generic standards. Immunity for industrial environment
EN IEC 61000-6-4	2019 - Electromagnetic compatibility (EMC). Generic standards. Emission standard for industrial environments

9 Appendix

9.1 CAN Messages

9.1.1 Send Messages

Transmit CAN message

The device sends out data messages at a rate defined by Send rate (parameter [↩️➡️ 109](#)) at the CAN Send ID (parameter [↩️➡️ 103](#)).

Byte 0	Byte 1	Byte 2	Byte 3	Byte 4	Byte 5	Byte 6	Byte 7
MUX Send	State DIs	State DOs	-	-	-	-	Status bits
1	see details	see details	0	0	0	0	see details

Details Byte 1

Physical state of the discrete inputs (corresponds to the LED).

Bit	Meaning
Bit 0 = 1	input 1 is triggered
Bit 1 = 1	input 2 is triggered
Bit 2 = 1	input 3 is triggered
Bit 3 = 1	input 4 is triggered
Bit 4 = 1	input 5 is triggered
Bit 5 = 1	input 6 is triggered
Bit 6 = 1	input 7 is triggered
Bit 7 = 1	input 8 is triggered

Details Byte 2

Physical state of the relays (corresponds to the LED).

Bit	Meaning
Bit 0 = 1	relay 1 is activated
Bit 1 = 1	relay 2 is activated
Bit 2 = 1	relay 3 is activated
Bit 3 = 1	relay 4 is activated
Bit 4 = 1	relay 5 is activated
Bit 5 = 1	relay 6 is activated
Bit 6 = 1	relay 7 is activated
Bit 7 = 1	relay 8 is activated

Details Byte 7

Bit	Meaning
Bit 0,1	LED C, bicolor:

Bit	Meaning
	00: off 01: red 10: green 11: orange
Bit 2,3	LED B, bicolor: 00: off 01: red 10: green 11: orange
Bit 4,5	LED A, bicolor: 00: off 01: red 10: green 11: orange
Bit 6 = 1	Button pressed (internally)
Bit 7 = 1	CAN bus error

9.1.2 Receive Messages

Receive CAN message

The device receives data messages at any time at the CAN Recieve ID (parameter [↩➡ 102](#)).

Byte 0	Byte 1	Byte 2	Byte 3	Byte 4	Byte 5	Byte 6	Byte 7
MUX Receive	Desired state D0s	-	-	-	-	-	-
1	see details	0	0	0	0	0	0

Details Byte 1

Desired state of the relays.

Bit	Meaning
Bit 0 = 1	set relay 1
Bit 1 = 1	set relay 2
Bit 2 = 1	set relay 3
Bit 3 = 1	set relay 4
Bit 4 = 1	set relay 5
Bit 5 = 1	set relay 6
Bit 6 = 1	set relay 7

Bit	Meaning
Bit 7 = 1	set relay 8

9.1.3 Start/Stop Message

CAN start/stop message

The device can receive a message at CAN-ID = 0. This is for Start/Stop of cyclically transmission of data via CAN bus.

Byte 0	Byte 1
"1" for start	CAN node ID or 0
"2" for stop	

If byte 1 is either the own CAN node ID or 0, the message is accepted.

Depending on the value of byte 0, it will either start its cyclical transmission or stop it.

Depending on parameter "Activate remote start/stop" (parameter [↩> 110](#)) the IKD2M-8/8 may not react to a message.

10 Third Party Software

The IKD2M-8/8 device uses the following third party software:

Name and Version of Software	Weblink	Remark
Free RTOS v10.5.1	http://www.FreeRTOS.org	Operating system

Table 7: Third party software

11 List Of Abbreviations

AC	Alternating current
AWG	American Wire Gage
CPU	Central processing unit (main processor)
DI	Discrete Input
DO	Discrete (relay) output
I	Current
ESD	Electrostatic discharge
GND	Common ground
LED	Light emitting diode
MCM	Thousands of Circular Mils
NC	Normally closed (break) contact
NO	Normally open (make) contact
P	Active power
PCB	Printed circuit board
P/N	Part number
PLC	Programmable logic control
S/N	Serial number
V	Voltage
W	Watt - unit of active power

Index

C

Contact person	9
Customer Service	9

I

Intended use	14
------------------------	----

P

Personnel	10
Protective equipment	13

S

Service	9
Symboles	
dans les instructions	8
Symbols	
in the instructions	7

T

Toolkit	28
-------------------	----

U

Use	14
---------------	----

W

Warranty	9
--------------------	---



Woodward GmbH

Handwerkstraße 29 — 70565 Stuttgart — Germany

Phone +49 (0) 711 789 54-510

Fax +49 (0) 711 789 54-101

industrial.support@woodward.com